



Trace metal determination in natural waters by automated solid phase extraction system and ICP-MS: The influence of low level Mg and Ca



Bo-Shian Wang, Chih-Ping Lee, Tung-Yuan Ho*

Research Center for Environmental Changes, Academia Sinica, 128, Sec. 2, Academia Road, Nankang, Taipei, Taiwan

ARTICLE INFO

Article history:

Received 30 January 2014

Received in revised form

27 April 2014

Accepted 28 April 2014

Available online 9 May 2014

Keywords:

Trace metal preconcentration

Nobias Chelate-PA1

Iminodiacetate resins

Matrix effect

GEOTRACES

ABSTRACT

A fully automated high pressure pretreatment system with Nobias Chelate-PA1 resin (PA1) was developed for trace metal determination by ICP-MS in natural waters. By varying the concentrations of Mg and Ca to mimic the concentrations in the eluate obtained by PA1 or iminodiacetate type resins, the overall analytical performance of the system was assessed for the determination of Al, V, Cr, Mn, Fe, Co, Ni, Cu, Zn, Y, Cd, Ag, Pb and REE. Comparing with the low mM level Mg and Ca (both ranging from 1 to 4 mM) eluted by iminodiacetate type resins, the eluate obtained by PA1 contains sub- μ M level Mg and Ca, which remarkably decrease matrix effect in ICP-MS analysis and significantly improve the analytical performance. With recovery better than 90% for most the trace metals examined, the accuracy was further verified through the analysis of five natural water reference materials with salinity spanning from 0 to 35‰. We have successfully applied the pretreatment system to determine trace metals in the seawater samples collected in the Western Philippine Sea through Taiwan GEOTRACES cruise.

© 2014 Elsevier B.V. All rights reserved.

1. Introduction

Trace metals are tightly associated with diverse physical, chemical or biological processes in natural aquatic environment and thus their concentrations and distributions provide important information to understand the mechanisms of material transport and cycling in the system [1–4]. For example, GEOTRACES, an ongoing international program aiming on the study of trace elements and their isotopes in the global ocean has obtained important findings to interpret marine geochemical and biogeochemical processes [5]. The major challenge to accurately quantify trace metals in seawater or other saline waters is to detect their extremely low concentrations in complicated matrix. Although inductively coupled plasma mass spectrometry (ICP-MS) possesses adequate sensitivity for direct metal analysis with quantification limit down to ppt or ppq levels [6], potential matrix-induced isobaric and polyatomic interferences combined with space-charge effect may influence analytical precision and accuracy [7,8]. Particularly, when measuring samples with various salinity, the different extents of matrix effect would cause accurate quantification to be complicated. To remove major salts in natural water samples without causing significant contamination is hence essential for trace metal analysis by ICP-MS.

Solid-phase extraction with chelating resins is recognized as one of the most effective approaches for matrix removal and trace metal preconcentration [9,10]. Several chelating resins have been commercially available and successfully applied to natural water pretreatment [5]. However, many of these resins have relatively high affinity to alkaline-earth elements and a narrow operating pH range for complete trace metal complexation, such as nitrilotriacetic acid (NTA) complexones [11], immobilized 8-hydroxyquinoline (8HQ) [12], and iminodiacetate (IDA) type resins such as Chelex-100 (BioRad) [13], Muromac A-1 (Muromachi) [14], Toyopearl AF-Chelate-650M (Tosoh Biosciences) [15], Metpac CC-1 (Thermo Fisher Scientific Dionex) [16]. On the contrary, the new dual-functionalized resin Nobias Chelate-PA1 (Hitachi; hereafter, PA1) is distinctly featured for extremely low retention of alkaline-earth elements accompanied with a relatively wide working pH [17,18], which has been successfully applied for the retrieval of transition metals and rare earth elements (REE) from seawater [17–22].

Considering the complicated steps involved in the pretreatment of trace metal analysis in seawater and other natural water, the use of fully programmed pretreatment system would substantially improve analytical capacity and reproducibility [15,16,23]. An automated high pressure ion chromatography (IC) pretreatment method was developed by utilizing an IDA-type resin (Dionex Metpac CC-1; hereafter CC-1) for trace metal chelation and matrix removal [16]. With maximum operation pressure up to 1500 psi, the system can stand back pressure and provide precise flow rate. The eluate obtained by using CC-1 in the system for seawater samples generally results in the concentrations up to

* Corresponding author. Tel.: +886 22653 9885x858; fax: +886 22783 3584.

E-mail address: tyho@gate.sinica.edu.tw (T.-Y. Ho).

4 mM Mg and 4 mM Ca (abbreviated as 'Mg–Ca' hereafter). The Mg–Ca matrix effect occurred in ICP-MS can be mostly corrected by using internal standard when the residual Mg and Ca in pretreated samples and standards are similar. However, the concentrations of Mg and Ca in natural waters may vary for more than three orders of magnitude, from less than 0.01 mM in freshwater to a few tenth mM in oceanic water. It may become problematic for trace metal quantification for samples with varying salinity to cause different Mg and Ca concentrations in the eluates. In this study, we first compared the matrix effect induced by the residual Mg and Ca retained in pretreated eluate obtained by using either IDA type and PA1 resins for trace metal quantification in ICP-MS. We then applied PA1 in the automated pretreatment system to evaluate its chelating efficiency for trace metals at various salinity, including Al, V, Cr, Mn, Fe, Co, Ni, Cu, Zn, Y, Ag, Cd, REE and Pb.

2. Experimental

2.1. Reagents and materials

The preparation of reagents and labware was carried out on Class-100 laminar flow benches in a positive-pressure clean laboratory. Polyethylene gloves were used to avoid Zn contamination. Ultrapure reagents including hydrochloric acid (HCl), nitric acid (HNO₃), ammonium hydroxide (NH₄OH) and acetic acid (CH₃COOH) were used (J.T. Baker ULTREX II). Ammonium acetate (NH₄OAc) buffer was prepared with the proportion of volume for CH₃COOH: NH₄OH: H₂O to be 4: 5: 9 then was adjust to pH 6.0 ± 0.1 by NH₄OH. For the Mg–Ca matrix effect test, the stock solutions of Mg and Ca were prepared by ultrapure grade magnesium chloride and calcium chloride powders (J.T. Baker) and were further purified by gravity flow through a polypropylene column with PA1 resin (Bio-Rad Poly-Prep, 8 × 40 mm with 10 mL reservoir).

All disposable plastic labware, including low-density polyethylene bottles (Nalgene), polypropylene centrifuge tubes (BD Biosciences), and pipette tips (Eppendorf), were acid-washed by the following three cleaning procedure: soaking in 1 M HCl (Baker Analyzed, J. T. Baker) for 24 h then rinsing with Milli-Q (Millipore) water, then soaking in 7 M HNO₃ (Baker Analyzed, J. T. Baker) for another 24 h then rinsing with Milli-Q water for 6 times. The reusable PFA containers (Savillex) were first soaked in 10% Micro 90 detergent (International Products Corporation) at least for 1 day then were rinsed by Milli-Q water thoroughly. The pre-cleaned PFA containers were further immersed in 1 M HCl for 24 h then were soaked in a 1 L PFA jar containing 7 M HNO₃ and were heated on a hotplate at 105 °C for 24 h. After cooling, the PFA containers were rinsed for 6 times by Milli-Q water. Right before use, each plastic labware was rinsed both inside and outside again by Milli-Q water.

2.2. PA1 resin

The resin was collected by incising PA1 cartridges with a pre-cleaned ceramic knife. After following the batch cleaning procedure [17], the resin was pipetted into empty 4 × 50 mm PEEK columns (DIONEX Metpac CC-1 column) with each aliquot of 50 µL. The solution in the columns was siphoned off by a peristaltic pump with a flow rate of 300 µL min⁻¹. The resin was further compacted by flushing the column with Milli-Q water with high pressure pump on the automated pretreatment system for 4 minutes then the column was refilled with additional resin. Refilling three to four times, the columns were fully packed and were ready to be deployed onto the automated system for pretreatment process. The automated pretreatment system was

cleaned right before sample processing by running 42 Milli-Q water samples.

2.3. Samples and standards

A trace metal mixture was prepared by mixing individual standard solution of the elements measured (High-Purity Standards) with final concentration of 500 ppb for each element. To carry out matrix effect test, the trace metal mixture was added into 0.3 M HNO₃ solutions to form trace metal concentrations of 1 ppb, and Mg and Ca of 0, 0.0025, 0.005, 0.1, 0.5, 1, 2 and 4 mM. Trace metal-stripped seawater was prepared by direct passing natural surface seawater through the three-stage columns with chelating resins: (1) large Chelex-100 column (24 mm i.d. quartz, with 166 g resin), (2) Chelex-100 column (8 mm i.d. polypropylene, with 1.2 g resin), and (3) PA1 column (8 mm i.d. polypropylene, with 0.6 g resin). This trace metal-stripped seawater was diluted further into eight salinity levels, i.e., 0, 3.5, 7.0, 10.5, 14.0, 21.0, 28.0 and 34.9‰, by Milli-Q water. The solutions were acidified to pH of approximately 1.8 by 3 M HNO₃ then doped with the 500 ppb standards to have the final standard concentrations to be 1 ppb.

Ten calibration standards were prepared in seawater matrix covering the trace metal concentration ranges observed in the oceans to quantify the concentrations in natural seawater and reference materials. Five natural water reference materials with different salinity were used to validate the method, including river water SLRS-5 (National Research Council Canada), estuarine water BCR-505 (Joint Research Centre, European Commission) and SLEW-3 (National Research Council Canada), nearshore seawater CASS-5 (National Research Council Canada), and seawater NASS-6 (National Research Council Canada). The SLRS-5 was diluted 2 and 10 times to determine most of the trace metals and 100 times for Fe. We have also applied the method to measure the seawater samples collected at a station (23°30'N, 126° of the Western Philippine Sea). The samples were collected by Teflon-lined GO-FLO bottles (General Oceanics) mounted on a trace metal clean rosette. Each sample was filtered through acid-cleaned 0.2 µm filter capsule (Polycap TC, Whatman), acidified by 3 M HNO₃ to pH 1.8, and stored in dark at room temperature. All the sample filtration and acidification were manipulated onboard in a trace metal clean van.

2.4. Preconcentration procedure

The preconcentration and matrix removal was performed programmatically on a Dionex ICS 3000 chromatograph [16]. The revised operation procedure is shown in Fig. 1. For example, A position (Fig. 1 and Table 1) stands for loading mode for column 2 and injection mode for column 1, and vice versa for B position (i.e., loading mode for column 1 and injection mode for column 2). Ammonium acetate buffer was purified online by a CC-1 column before mixing with samples. The pH of each acidified sample was adjusted to pH 6.0 ± 0.1 by adding 5 mL of 1.8 M NH₄OAc (see column C2 in Table 1). Each sample of 38 mL including a 3-mL loop flushing was consumed and eventually a 5-mL eluate was collected automatically in a 15 mL pre-cleaned screw-capped polypropylene centrifuge tube, resulting in a concentration factor of 7. Before ICP-MS analysis, an aliquot of 0.1 mL 50 ppb of Rhodium (Rh) in 0.3 M HNO₃ was added manually in each pretreated sample to obtain a final Rh concentration to be 1 ppb. Procedural blank and chemical yield of trace metals through the automated pretreatment system were evaluated every batch based on six Milli-Q waters and reference materials CASS-5 and NASS-6.

A manual gravity-flow column method was also employed for salinity test, to be as an analog for the automated pretreated

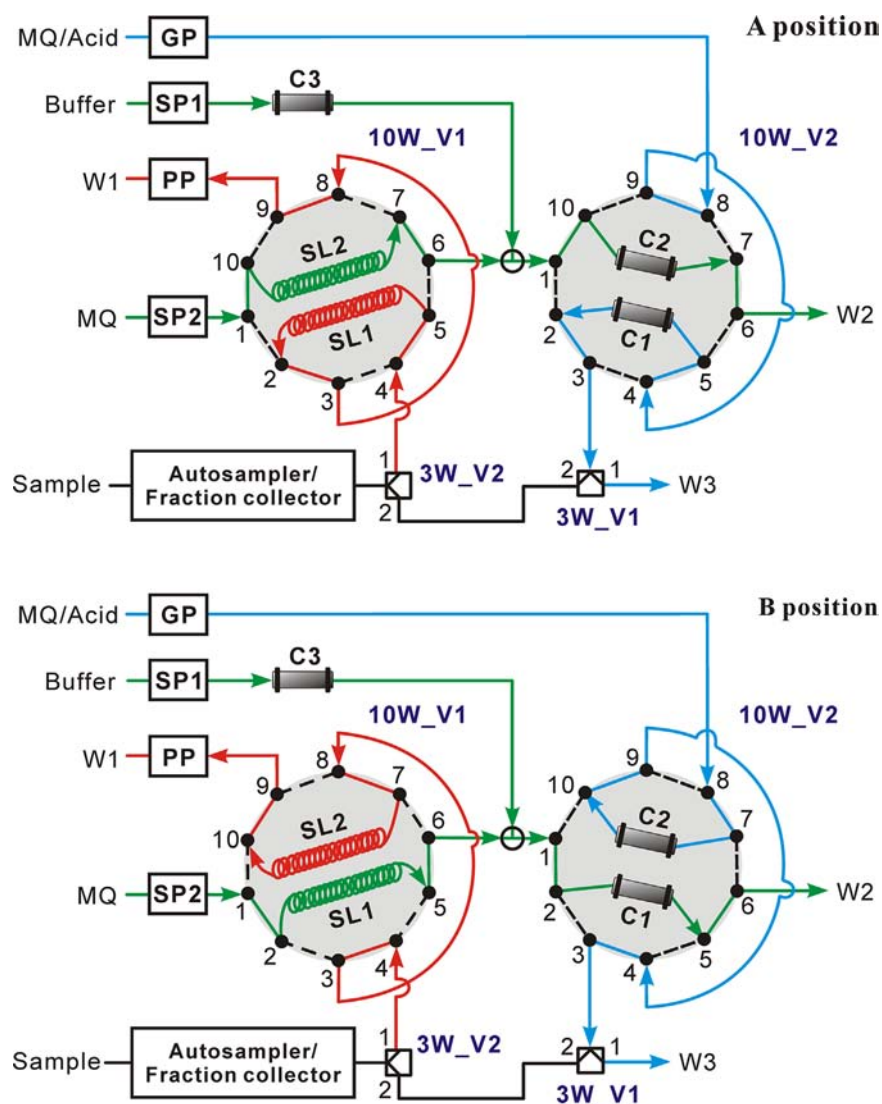

Fig. 1. The schematic configuration of the automated IC manifold. GP, SP and PP denote gradient pump, single pump and peristaltic pump. SL1 and SL2 stand for sample loops 1 and 2; C1, C2 stand for resin columns 1 and 2 with PA1, and C3 is CC-1 pre column for buffer solution. W1, W2 and W3 stand for waste solution. The detailed procedures for sample uptake, chelation and elution in the manifold are describe in our previous study [16] with minor modification shown in Table 1.

Table 1

The operating procedure for preconcentration and column cleaning by the IC automated system shown in A position in Fig. 1.

| Time | Sample probe | SL1 ^a | SL2 ^a | C1 ^a | C2 ^a |
|-------|--|----------------------------------|-------------------------------------|---|--|
| -0.10 | Rinse | | | | |
| 0.00 | Go to sample | Sample (S3 ⁺) uptake | Sample (S2 ⁺) injection | MQ rinse (0.75 mL min ⁻¹) | Sample (S2) loading (3.0 mL min ⁻¹) |
| 5.00 | Needle home | Sample uptake stop | (3 mL min ⁻¹) | | associated with buffer ^b conditioning (0.5 mL min ⁻¹) |
| 5.10 | Rinse on | Sample (S3) in SL1 | | | |
| 5.30 | Rinse off | | | | |
| | Go to Frac_waste | | | | |
| 5.50 | Loop backwashing | | | | |
| 9.50 | Loop backwashing stop | | | | |
| 9.60 | Rinse on | | | | |
| 10.00 | Rinse off | | | MQ rinse (stepwise from 0.75 to 2.0 mL min ⁻¹) | Buffer rinse |
| 12.25 | | | Sample injection stop | MQ rinse stop | |
| 12.26 | Go to Frac_sample | | MQ ^b in SL2 | Acid ^b elution start (2.0 mL min ⁻¹) | |
| 12.66 | Eluent (S1 ⁺) collection start | | | Elution stop, and additional acid cleaning (2.0 mL min) | |
| 15.16 | Eluent collection stop | | | MQ cleaning (3.0 mL min ⁻¹) | Sample (S2) in C2 |
| 15.46 | stop | | | | |
| 15.81 | Program finish | | | | |

^a SL1 and SL2 are sample loops 1 and 2; C1 and C2 are columns 1 and 2; S1, S2 and S3 denote samples 1, 2 and 3.

^b MQ: Milli-Q water; buffer: 1.8N ammonium acetate; acid: 2N HNO₃ (diluted to 1 N by MQ through a DXP pump).

method. A precleaned empty polypropylene column (Bio-Rad Poly-Prep, 8 × 40 mm with 10 mL reservoir) was filled with PA1 resin with volume equivalent to the column used in the automated pretreatment system. The packed column was used to pretreat the 1 ppb trace metal solutions with eight salinity levels mentioned in Section 2.3. Two different eluents were examined in the gravity column experiment, including a 5 mL aliquot of 1 M HNO₃ that normally used in the automated pretreatment system and a 10 mL 3 N HNO₃.

2.5. Instrumentation

A sector field ICP-MS Element XR (Thermo Fisher Scientific) was executed with a SC-Fast autosampler with a 2 mL sample loop (Elemental Scientific). Dry plasma mode was used to reduce oxide and hydride interferences through an Apex HF-Spiro membrane desolvation device (Elemental Scientific). Signal sensitivity was tuned to achieve 1 million counts per second (cps) per ppb for ¹¹⁵In, with signal stability around 1% and oxide level below 0.5%. When Ni sampler and H-skimmer cones (Spectron) are used, we have observed that Ni background signals are generally up to 1000 cps. We found that the background Ni signals can be significantly reduced to less than 50 cps by injecting a 4 mM Mg–Ca solution for a couple of minutes during instrument warm up period. The deposition effect can last for at least 6-hr during measurement.

The isotopes, including ¹⁰⁷Ag, ¹¹¹Cd, ¹³⁹La, ¹⁴⁰Ce, ¹⁴¹Pr, ¹⁴³Nd, ¹⁴⁶Nd, ¹⁴⁷Sm, ¹⁵³Eu, ¹⁵⁷Gd, ¹⁵⁹Tb, ¹⁶³Dy, ¹⁶⁵Ho, ¹⁶⁷Er, ¹⁶⁹Tm, ¹⁷³Yb, ¹⁷⁵Lu, ²⁰⁷Pb and ²⁰⁸Pb were analyzed at low resolution ($M/\Delta M \sim 300$), and ²⁷Al, ⁴³Ca, ⁴⁹Ti, ⁵¹V, ⁵³Cr, ⁵⁵Mn, ⁵⁶Fe, ⁵⁹Co, ⁶⁰Ni, ⁶¹Ni, ⁶³Cu, ⁶⁴Zn, ⁶⁵Cu and ⁶⁶Zn were measured under medium resolution mode ($M/\Delta M \sim 5000$). The entire acquisition time was about 3 min including sample uptake, signal acquisition, and cleaning introduction system. Mass drift at medium resolution was minimized by employing the 'lock mass' function on ⁴⁰Ar⁴⁰Ar⁺ dimer. The measured signals were further corrected by internal standard Rh for all of the elements determined. Potential interferences caused by polyatomic ions or doubly charges were estimated by monitoring ⁸⁹Y¹⁶O⁺ (LR), ⁸⁹Y⁴⁰Ar⁺ (LR), ¹⁰³Rh¹⁶O⁺ (LR), ¹⁰³RhH⁺ (LR and MR), ⁹⁷Mo⁺⁺ (MR), and ¹⁰³Rh⁺⁺ (MR). The

formation of oxides and hydrides were generally better than 0.7% and 0.2%, respectively. None of Rh⁺⁺ was observed.

3. Results and discussion

3.1. Matrix effect of Mg and Ca for ICP-MS

The concentration level of Mg and Ca in the eluate obtained by using CC-1 resin to process seawater generally ranges from 1 to 4 mM. To investigate the effect of Mg–Ca background on elemental sensitivity of trace metals in ICP-MS, a matrix doping test was carried out with the Mg and Ca concentrations ranging from 0 to 4 mM. Based on the response patterns with different Mg–Ca concentrations in matrix, we arbitrarily separate the trace metals measured to four groups (Fig. 2A–D). For many of the measured trace metals, including Al, V, Cr, Mn, Fe, Co, Ni, Zn, Y, Ag, Cd and Pb, the signals were substantially suppressed with increasing Mg and Ca concentrations and dropped about 80% at 4 mM despite they show slight enhancement within 0.05 mM (Fig. 2A). The responses of most REE to the matrix effect are similar to the trace metals mentioned above (Fig. 2B). Three REE elements, including La, Ce and Pr, behave differently, declining 40% at 4 mM while increasing 20% within 0.1 mM (Fig. 2C). The signal inhibition can be mainly attributed to the dominant space-charge competition between targeted trace metals and Mg and Ca ions [7]. On the other hand, the signal enhancement at low Mg–Ca matrix is most likely due to the formation of Mg- and Ca- based aerosols facilitating the transmission of trace metals to plasma. The responses of Cu to the matrix effect is particularly sensitive, showing significant signal decrease at 0.0025 mM Mg–Ca concentration (Fig. 2D). Aside from the influence of the matrix effect, serious salt accumulation on skimmer cone of ICP-MS after a few hours measurement would also cause significant signal drop.

Internal standard Rh was used to compensate the matrix effect caused by Mg and Ca (Fig. 2E–H). Within 0.05 mM Mg–Ca concentration, the deviation of normalized signals to the signals obtained at zero Mg–Ca concentration are smaller than 10% for Al,

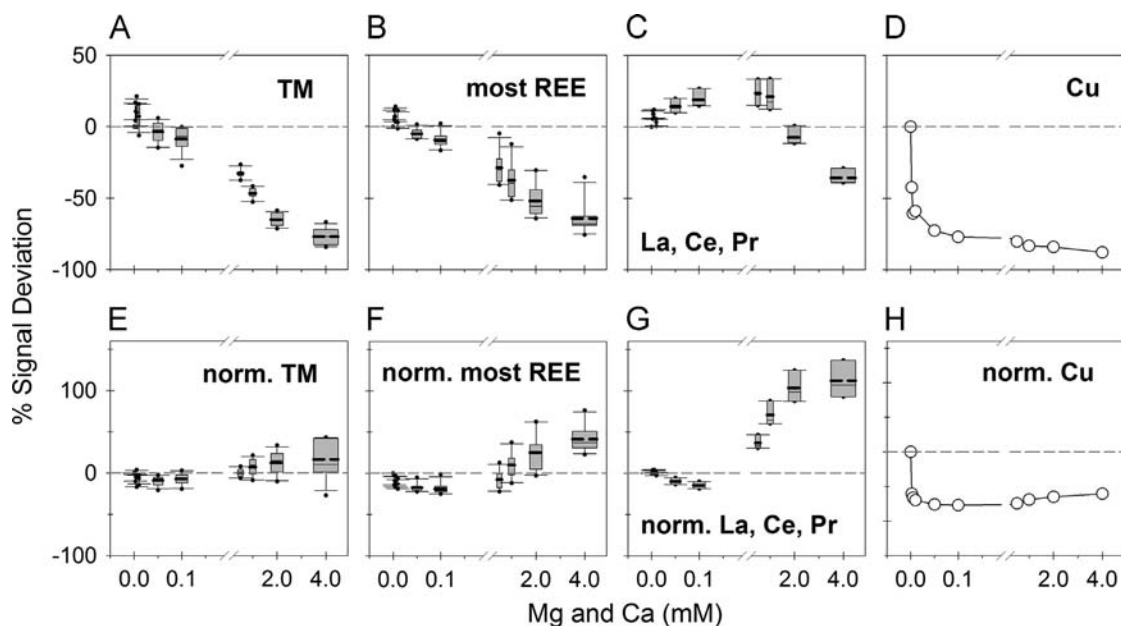

Fig. 2. The sensitivity variation of trace metals as a function of Mg–Ca matrix concentration. The concentrations of Mg and Ca are same and equal to the number on the X axis. The deviation percentage (%) is relative to the intensity without adding Mg and Ca. The data shown are the average value of the four repeated experiments. The elements measured are separated into four groups, including (A) most of the trace metals (TM) including Al, V, Cr, Mn, Fe, Co, Ni, Zn, Y, Ag, Cd and Pb, (B) most REE, (C) La, Ce, Pr, and (D) Cu without internal standard correction. The variations of the elements normalized by Rh are shown from E to H. Box plot, except Cu, is used to illustrate the distribution of the signal deviation. Bold dash line in the box represents the mean value of all elements.

V, Cr, Mn, Fe, Co, Ni, Zn, Y, Ag, Cd and Pb, and on average gradually increase to 15% at Mg–Ca concentration to be 4 mM (Fig. 2E). Similarly, the deviations of all REE are smaller than 10% with Mg–Ca concentrations within 0.05 mM (Fig. 2F and G) and the deviations of most REE increased with Mg–Ca concentration and reach 60% at Mg–Ca concentration to be 4 mM (Fig. 2E). However, the deviations of La, Ce and Pr increase remarkably with increasing Mg–Ca concentrations and reach 100% with Mg–Ca concentrations larger than 2 mM (Fig. 2G). The normalized Cu is significantly underestimated, decreasing 60–76% at Mg–Ca concentrations above 0.0025 mM (Fig. 2H). Using Sc, Y or In as internal standards, similar deviation patterns are observed for all of the elements measured (not shown in this study). These results indicate that the matrix effect caused by different Mg–Ca concentrations at low mM level vary significantly and may not be properly corrected by internal standards. The deviations are particularly large for La, Ce, Pr, and Cu. It is thus essential to obtain pretreated eluates with extremely low Mg and Ca concentrations to accurately quantify trace metal concentrations in natural waters with varying Mg–Ca concentrations by ICP-MS with membrane desolvation system.

3.2. Influence of salinity on PA1 affinity

The affinity and selectivity of chelating resins for different trace metals depend on the conditions of pH, ionic strength, and other complexed species in samples. For instance, Chelex-100, an IDA-functionalized resin, possesses decreasing chelating affinity for trace metals in seawater than freshwater medium [13], which is caused by the presence of complexed metal species and competitive cations, particularly Mg and Ca. To evaluate the affinity of PA1 resin on trace metals under different salinities, we used both the automatic system and manual gravity-flow column method to examine trace metal recovery among eight salinity levels ranging from 0 to 34.9‰. The chemical yield shown for most of the trace

metals measured is higher than 90% by either the automatic or manual pretreatment, except Cr (VI) and Ag (Fig. 3).

By using both automatic and manual gravity elution methods, the recovery for Cr (VI) remains low at all the testing salinity, generally ranging from 20% to 40% (Fig. 3D). The recovery of Ag under various salinity exhibits different patterns between the two processing methods. With automated pretreatment method, the recovery reaches 90% at salinity 0 and gradually drops to 60% with salinity increasing to 35‰ (Fig. 3C). While using gravity column method with 5 mL 1 M HNO₃ eluant, the recovery decreases from 90% at salinity 0 to about 65% at salinity ranging from 3.5‰ to 35‰. Higher Ag recovery can be achieved by increasing the acidity and volume of the eluent from 5 mL 1 N to 10 mL 3 M nitric acid at salinity within 21‰. We suspect that the formation of silver complex ions at elevated salinity may bind strongly with PA1 (cf. [24]). Overall, this test shows that the chelating affinity of PA1 for trace metals, including Al, V, Mn, Fe, Co, Ni, Cu, Zn, Y, Cd, REE and Pb are sufficiently high in aqueous samples with salinity ranging from 0 to 35‰, indicating the sufficient capacity of PA1 for trace metal preconcentration from aqueous samples with diverse salinity either using both automatic and manual gravity elution methods.

3.3. Affinity of Cr and other trace metals on PA1 and CC-1

We found that the chelating affinity of PA1 on Cr is relatively low (Table 2), which is different from the previous study [17]. The recovery obtained was only 17% under conditioning pH 1.8, varied from 20 to 40% with pH increasing from 3.1 to 8.2, and remained around 30 ± 10% by increasing eluate acidity and volume from 5 mL 1 M to 10 mL 3 M HNO₃ (Fig. 3C). On the contrary, IDA-type resins exhibit rather high affinity for Cr. For example, Chelex-100 and Muromac A-1 can chelate Cr (III) [25,26] and CC-1 complex

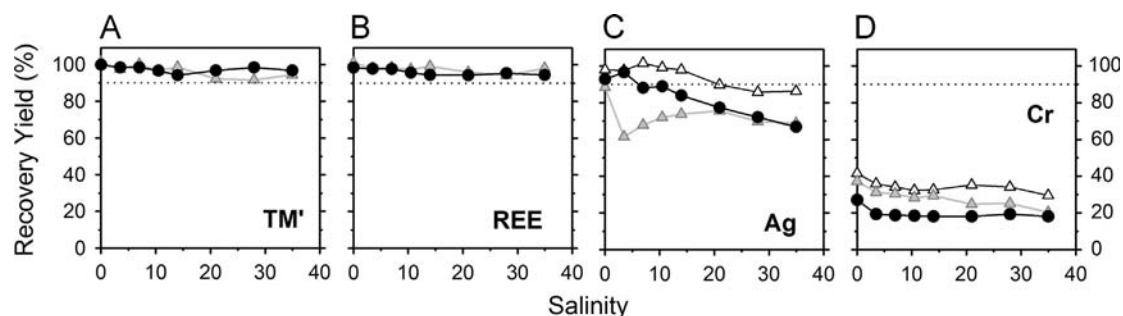

Fig. 3. Effect of salinity (per mil) on PA1 chelating efficiency for (A) most of the trace metals (TM') including Al, V, Mn, Fe, Co, Ni, Cu, Zn, Y, Cd and Pb, (B) REE, (C) Ag, and (D) Cr (VI) either using automated pretreatment system (filled circle) or manual gravity elution (gray triangle), eluted with 5 mL 1 M HNO₃. Open triangles shown in (C) and (D) represent the recovery by using 10 mL 3 M HNO₃ eluent. Dot lines represent 90% recovery threshold.

Table 2

Metal recovery by using Nobias Chelate-PA1 and Metpac CC-1 in Milli-Q and seawater via the same IC program.

| Element ^a | Al | Cr | Mn | Ag | Cd | TM ^b | REE ^c | Na | Mg | Ca |
|--|-----|-------------------|-----|-------------------|------|-----------------|------------------|-------------------|--------------------|--------------------|
| Recovery (%; preconcentrated from 35 mL to 5 mL) | | | | | | | | | | |
| PA1_IC-MQ | 90 | < 40 ^d | 100 | > 85 | 100 | 100 | > 90 | n.a. ^e | n.a. | n.a. |
| PA1_IC-SW | 93 | < 30 ^d | 100 | > 70 ^d | 100 | 100 | > 90 | 0 ^f | 0.001 ^f | 0.002 ^f |
| CC-1_IC-MQ | 100 | > 95 | 100 | 95 | > 90 | 100 | > 90 | n.a. | n.a. | n.a. |
| CC-1_IC-SW | 77 | > 95 | 80 | 42 | 83 | 100 | > 90 | 0.002 | 0.28 | 1.95 |

^a The original Na, Mg and Ca concentrations (in mM) are equal to open ocean seawater. Al, Cr, Mn, Ag and Cd are 3.7, 0.8, 1.1, 0.01 and 0.2 nM.

^b TM refers to trace metals (nM) including V (4.7), Fe (0.7), Co (0.02), Ni (1.7), Cu (1.3), Zn (1.5) and Pb (0.02).

^c REE (pM): La (18), Ce (38), Pr (4.8), Nd (20), Sm (4.4), Eu (1.3), Gd (4.3), Tb (0.7), Dy (3.9), Ho (0.8), Er (2.2), Tm (0.3), Yb (2.0), Lu (0.3).

^d Unstable recovery.

^e n.a. stands for not available.

^f The numbers stand for the average values of triplicate pretreatment. The retention of Na is less than 0.0005%.

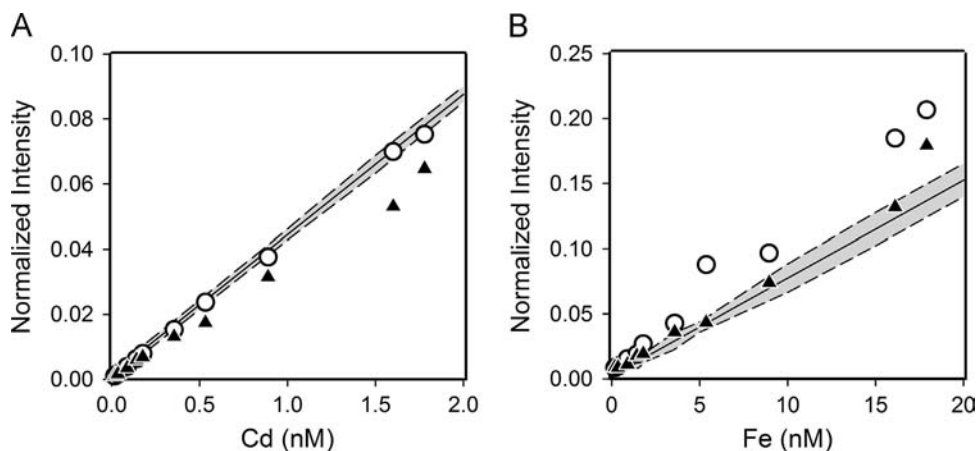

Fig. 4. The comparison of the slopes of the calibration curves obtained by PA1 and CC-1 resins. The signals were all normalized to internal standard Rh for Cd (A) and Fe (B). The solid lines with shaded area represent the average of three standard calibration curves with 2 standard deviations, including trace metal standards prepared in Milli-Q water, trace metals in Milli-Q water and pre-concentrated by PA1 resin, and trace metals in seawater pre-concentrated by PA1 resin. The results obtained by CC-1 resin in Milli-Q and seawater matrices are shown with open circle and solid triangle, respectively.

Table 3

Analytical results for the trace metals in the certified reference materials (unit: nM).

| Element ^a | BLK ^a | MDL ^b | SLRS-5 | | SLEW-3 | | BCR-505 | | CASS-5 | | NASS-6 | |
|----------------------|------------------|------------------|------------------------|--------------------------|------------------------|--------------------------|-------------|------------------|------------------------|------------------|------------------------|------------------|
| | | | This work ^c | Certified | This work ^c | Certified | This work | Certified | This work ^c | Certified | This work ^c | Certified |
| V | 0.001 | 0.004 | 6.37 ± 0.32 | 6.22 ± 0.65 | 55.5 ± 8.5 | 50.4 ± 6.1 | 72.7 ± 4.6 | 63.8 | 25.4 ± 3.2 | 25.9 ± 2.8 | 27.4 ± 4.6 | 28.7 ± 3.3 |
| Mn | 0.005 | 0.01 | 78.0 ± 7.5 | 78.8 ± 3.3 | 30.4 ± 8.2 | 29.3 ± 4.0 | 18.3 ± 3.2 | 13.2 | 49.3 ± 3.2 | 47.7 ± 3.6 | 9.6 ± 1.7 | 9.7 ± 0.9 |
| Fe | 0.07 | 0.19 | 1620 ± 82 | 1633 ± 104 | 10.4 ± 2.1 | 10.2 ± 1.1 | 20.2 ± 3.4 | 19.0 ± 4.0 | 25.2 ± 4.9 | 25.8 ± 2.0 | 8.1 ± 1.5 | 8.9 ± 0.8 |
| Co | 0.001 | 0.001 | 0.89 ± 0.17 | 0.85 | 0.72 ± 0.09 | 0.71 ± 0.17 | 1.08 ± 0.08 | 1.70 ± 0.3 | 1.54 ± 0.13 | 1.61 | 0.23 ± 0.03 | 0.25 |
| Ni | 0.04 | 0.03 | 7.69 ± 0.4 | 8.11 ± 1.1 | 20.0 ± 2.5 | 21.0 ± 1.2 | 24.5 ± 2.2 | 24.1 ± 2.0 | 5.3 ± 0.4 | 5.6 ± 0.4 | 5.1 ± 0.7 | 5.1 ± 0.4 |
| Cu | 0.02 | 0.19 | 294 ± 62 | 274 ± 20 | 26.1 ± 2.2 | 24.4 ± 1.9 | 31.4 ± 3.5 | 29.4 ± 1.5 | 6.2 ± 0.7 | 6.0 ± 0.4 | 3.71 ± 0.64 | 3.90 ± 0.40 |
| Zn | 0.09 | 0.21 | 13.4 ± 1.5 | 12.9 ± 1.4 | 2.98 ± 0.6 | 3.07 ± 0.6 | 184 ± 29 | 172 ± 11 | 11.7 ± 0.7 | 11.0 ± 1.0 | 4.64 ± 1.81 | 3.93 ± 0.30 |
| Y | 0.0004 | 0.001 | 1.28 ± 0.40 | 1.35 ± 0.11 ^d | 0.45 ± 0.11 | 0.47 ± 0.02 ^e | 0.28 ± 0.06 | nd. ^f | 0.25 ± 0.02 | nd. ^f | 0.27 ± 0.04 | nd. ^f |
| Cd | 0.001 | 0.0005 | 0.06 ± 0.003 | 0.05 ± 0.01 | 0.46 ± 0.05 | 0.43 ± 0.04 | 0.82 ± 0.06 | 0.80 ± 0.04 | 0.21 ± 0.02 | 0.19 ± 0.02 | 0.27 ± 0.07 | 0.28 ± 0.02 |
| Pb | 0.001 | 0.001 | 0.41 ± 0.14 | 0.39 ± 0.03 | 0.03 ± 0.01 | 0.04 ± 0.01 | 0.19 ± 0.02 | 0.24 ± 0.14 | 0.04 ± 0.01 | 0.05 ± 0.01 | 0.03 ± 0.01 | 0.03 ± 0.01 |

^a Procedural blank includes the blanks from the reagents, IC pretreatment, and ICP-MS analysis ($n=4$). Aluminum results are now shown due to high blank of 1.8 nM.

^b Method detection limit (MDL) is defined as 3 s.d. of seven Milli-Q blanks that were processed by IC method with PA1 resin.

^c Data shown are mean ± 2 s.d. accumulated from two SLRS-5 and SLEW-3 standard bottles and six for CASS-5 and NASS-6.

^d Reported by Heimburger et al. [28].

^e Reported by Bayon et al. [27].

^f Not determined.

Table 4

Analytical results for REE in the certified reference materials (unit: pM).

| Element | BLK ^a | MDL ^b | SLRS-5 | | SLEW-3 | | BCR-505 | CASS-5 | | NASS-6 |
|---------|------------------|------------------|------------------------|------------|------------------------|-----------|-----------|------------------------|------------|-----------|
| | | | This work ^c | Ref. [28] | This work ^c | Ref. [27] | | This work ^c | Ref. [29] | |
| La | 0.11 | 0.65 | 1423 ± 121 | 1410 ± 80 | 62 ± 6 | 55 ± 6 | 50 ± 7 | 56 ± 10 | 57 ± 3 | 77 ± 9 |
| Ce | 0.14 | 0.69 | 1750 ± 89 | 1680 ± 110 | 51 ± 4 | 47 ± 4 | 57 ± 8 | 23 ± 4 | 24 ± 1 | 32 ± 6 |
| Pr | 0.07 | 0.10 | 336 ± 27 | 330 ± 18 | 12 ± 1 | 12 ± 1 | 8 ± 2 | 8 ± 1 | 8 ± 0.1 | 12 ± 2 |
| Nd | 0.25 | 1.43 | 1294 ± 102 | 1280 ± 140 | 57 ± 9 | 55 ± 2 | 49 ± 6 | 34 ± 2 | 35 ± 1 | 47 ± 8 |
| Sm | 0.18 | 0.21 | 218 ± 26 | 220 ± 20 | 50 ± 4 | 48 ± 0.4 | 35 ± 5 | 8 ± 1 | 8 ± 0.1 | 9 ± 1 |
| Eu | 0.06 | 0.20 | 38 ± 3 | 37 ± 9 | 3.5 ± 0.1 | 3 ± 0.2 | 2.8 ± 0.5 | 1.2 ± 0.1 | 1.3 ± 0.02 | 1.8 ± 0.2 |
| Gd | 0.06 | 0.20 | 154 ± 26 | 158 ± 19 | 20 ± 1 | 20 ± 3 | 17 ± 3 | 7.3 ± 0.7 | 7.7 ± 0.2 | 8.5 ± 1.8 |
| Tb | 0.01 | 0.01 | 22 ± 3 | 20 ± 4 | 3.1 ± 0.1 | 2.9 ± 0.2 | 2.4 ± 0.6 | 1.3 ± 0.03 | 1.1 ± 0.02 | 1.5 ± 0.6 |
| Dy | 0.02 | 0.07 | 113 ± 6 | 112 ± 15 | 22 ± 1 | 21 ± 1 | 14 ± 2 | 8 ± 1 | 7.5 ± 0.1 | 10 ± 1 |
| Ho | 0.01 | 0.01 | 22 ± 4 | 22 ± 3 | 5.4 ± 0.4 | 6 ± 0.2 | 4 ± 0.5 | 2.0 ± 0.2 | 1.9 ± 0.03 | 2.4 ± 0.7 |
| Er | 0.02 | 0.06 | 65 ± 9 | 63 ± 6 | 15 ± 1 | 16 ± 1 | 12 ± 1 | 6.4 ± 0.8 | 6.4 ± 0.1 | 8 ± 1 |
| Tm | 0.01 | 0.01 | 8 ± 2 | 7.7 ± 1.8 | 1.8 ± 0.3 | 2 | 2.0 ± 0.3 | 0.9 ± 0.1 | 0.9 ± 0.01 | 1.1 ± 0.3 |
| Yb | 0.02 | 0.05 | 54 ± 4 | 54 ± 4 | 12 ± 3 | 11 ± 1 | 17 ± 3 | 6.3 ± 1.2 | 6.3 ± 0.1 | 7.6 ± 1.6 |
| Lu | 0.05 | 0.06 | 8.5 ± 1 | 8.6 ± 1 | 1.8 ± 1 | 1.7 ± 0.1 | 3.0 ± 0.5 | 1.1 ± 0.1 | 1.1 ± 0.02 | 1.2 ± 0.4 |

^a Procedural blank includes the blanks from the reagents, IC pretreatment, and ICP-MS analysis ($n=4$).

^b Method detection limit (MDL) is defined as 3 s.d. of seven Milli-Q blanks that were processed by IC method with PA1 resin.

^c Data shown are mean ± 2 s.d. accumulated from two SLRS-5 and SLEW-3 standard bottles and six for CASS-5 and NASS-6.

Cr (VI) effectively [16]. The species-specific property of IDA resins on Cr may be useful for studying Cr speciation in natural waters.

Elevated Mg and Ca matrix concentrations in standards may cause systematic change of slope of calibration curve. Although the chelating ability of CC-1 resin is high for most of the trace metals determined in this study, including V, Fe, Co, Ni, Cu, Zn, REE, and Pb (Table 2), we found that the slopes of calibration curves obtained from CC-1 resin are different from the ones obtained by PA1. Taking Cd and Fe as examples, the slopes of the calibration curves directly obtained from Milli-Q water matrix are identical to that obtained from the PA1 pretreated standards prepared either in Milli-Q water or seawater matrix (Fig. 4A and B). Nevertheless, the calibration slopes obtained from the automated pretreatment system with CC-1 resin are slightly different for standards prepared in Milli-Q and seawater matrices. The results infer that using CC-1 or other conventional chelating resins with relatively high affinity on alkaline-earth elements may lead to large quantifying uncertainty for trace metals in samples with various salinity and the corresponding extent of matrix effect. Another side effect by using CC-1 is that the production of polyatomic interferences by substantial Mg and Ca matrix may influence the analytical accuracy, such as $^{40}\text{Ca}^{15}\text{N}$ on ^{55}Mn , $^{40}\text{Ca}^{16}\text{O}$ on ^{56}Fe , $^{24}\text{Mg}^{36}\text{Ar}$ on ^{60}Ni , $^{48}\text{Ca}^{15}\text{N}$ on ^{63}Cu , $^{24}\text{Mg}^{40}\text{Ar}$ on ^{64}Zn , $^{25}\text{Mg}^{40}\text{Ar}$ on ^{65}Cu and $^{26}\text{Mg}^{40}\text{Ar}$ on ^{66}Zn . Combining with matrix-induced signal suppression, the increase of polyatomic interference as increasing Mg–Ca matrix concentration may lead to larger analytical inaccuracy. To evaluate potential matrix effect for pretreated samples using IDA or other chelating resins with higher retention for Mg and Ca, it is suggested to monitor $^{43}\text{Ca}^+$ or $^{46}\text{Ca}^+$ during ICP-MS analysis.

Pai et al. [13] reported that the chelating affinity of Chelex-100 for Mn and Cd were lower in seawater than in freshwater media and the equilibration time for the chelation was prolonged in seawater matrix. We also observed that the recoveries of Al, Mn, Ag and Cd by CC-1 are lower in seawater than in Milli-Q water matrix (Table 2). Therefore, the relatively low CC-1 recovery on trace metals in seawater matrix is possibly due to the occupation of chelating sites by other competing ions, such as Mg and Ca.

3.4. Accuracy and reproducibility

The accuracy of the automated pretreatment system with PA1 resin was evaluated by using five natural water reference materials with salinity spanning from freshwater to seawater, including SLRS-5, SLEW-3, BCR-505, CASS-5, and NASS-6. The results for almost all the trace metals determined are in agreement with either the certified or consensus values (Tables 3 and 4) [27–29], with differences generally less than 10%. The differences of the REE concentrations are generally within 20% between the measured and the consensus values for SLRS-5, SLEW-3 and CASS-5 (Table 4). We also report the REE concentrations for BCR-505 and NASS-6, in which the REE concentrations have not been certified yet. As mentioned previously, the analysis of Cu by ICP-MS are susceptible to Mg–Ca matrix effect even with concentrations as low as 25 μM in sample solution (Fig. 2F). Using the pretreatment system with PA1 resin, the Mg and Ca concentrations are generally decreased to 0.5 and 0.2 μM in the eluate, respectively. We found that all the measured Cu concentrations in the reference materials show good consistency with the certified values. We have applied

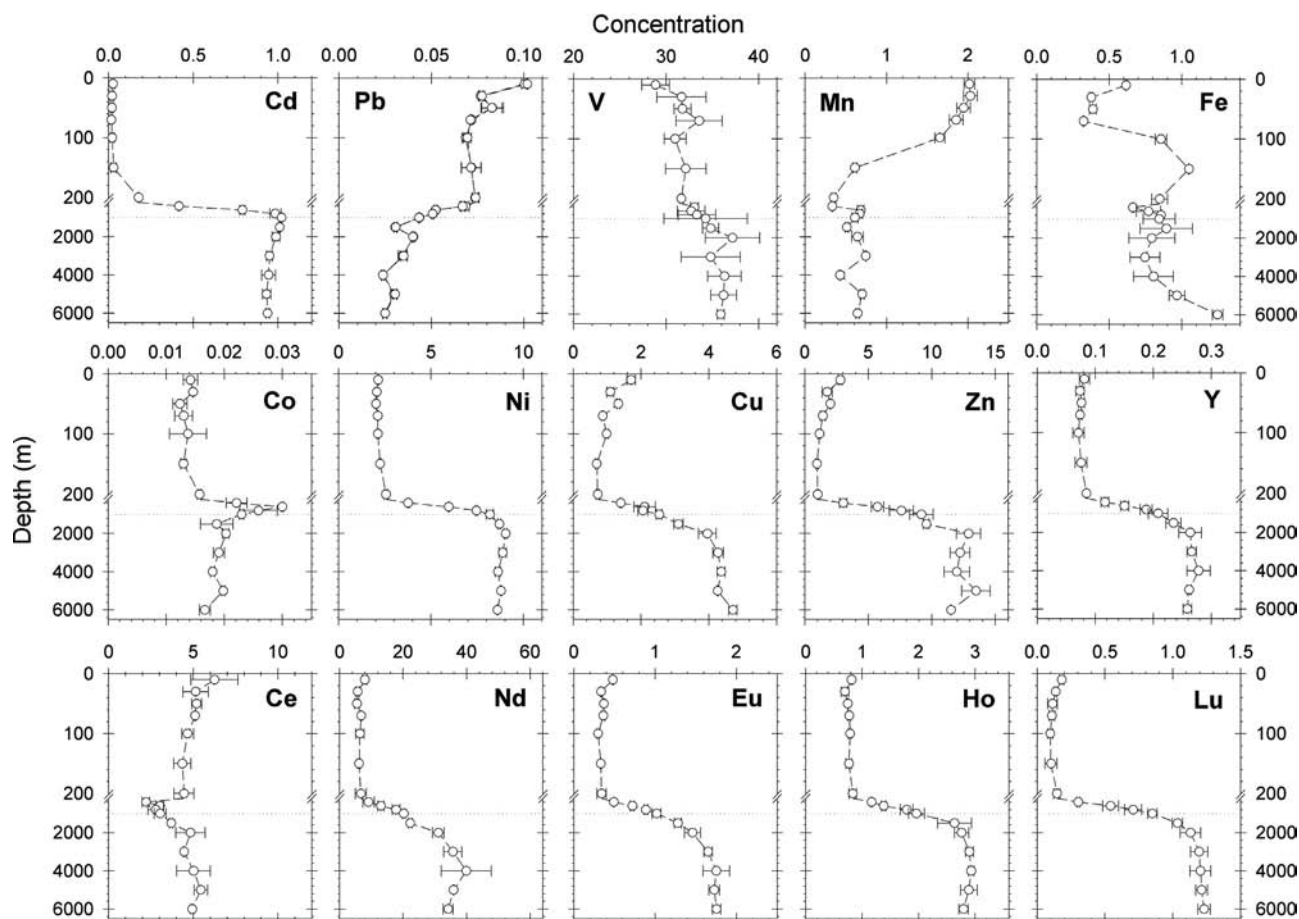

Fig. 5. The vertical profiles of dissolved trace metals collected at the station ($23^{\circ}30'\text{N}$, 126° in the Western Philippine Sea during 2013 Taiwan GEOTRACES cruise. The concentration unit for the trace metals and the five selected REE are nM and pM, respectively. The depth scale is enlarged in the top 200 m. The horizontal dotted lines denote 1000 m and the error bars represent the average deviation of duplicate analysis.

the improved pretreatment method to seawater samples collected in the Western Philippine Sea. The concentration profiles exhibit satisfactory results (Fig. 5), which are comparable to the previous observation in the North Pacific Ocean [30]. Overall, the automated pretreatment method with PA1 resin coupled with ICP-MS analysis can accurately and precisely determine the concentrations of transition metals and rare earth elements in natural water samples with various salinity.

4. Conclusions

A method combined an automated pretreatment system with PA1 resin and ICP-MS analysis was developed and evaluated for the determination of trace metals in natural waters. The sub- μM Mg and Ca concentrations yielded from the pretreatment system with PA1 resin result in better analytical performance while comparing with conventional IDA-functionalized resins generally yielding low mM Mg and Ca concentrations. The chelating affinity of PA1 resin in the pretreatment system remains substantially high for trace metals in natural water samples with a wide salinity range spanning from freshwater to seawater. We have validated the accuracy of the concentrations of transition metals and REE by the method in five natural water reference materials and the natural seawater samples collected in the Western Philippine Sea.

Acknowledgments

The authors thank the assistance provided by the staffs of the R/V Ocean Researcher 5 for seawater sampling. Special appreciation is also given to the anonymous reviewers for their critical comments and Gary Christian for handling the manuscript. This research was supported by the National Science Counsel with Grant number NSC-102-2611-M-001-004-MY3 and by the Academia Sinica through the grant entitled “Ocean Acidification: Comparative biogeochemistry in shallow water tropical coral reef ecosystems in a naturally acidic marine environment.”

References

- [1] K.W. Bruland, M.C. Lohan, 6.02—controls of trace metals in seawater, in: H. Elderfield (Ed.), *Treatise on Geochemistry*, Pergamon, Oxford, 2003, pp. 23–47.
- [2] E. Callender, 9.03 – heavy metals in the environment – historical trends, in: H. Elderfield (Ed.), *Treatise on Geochemistry*, Pergamon, Oxford, 2003, pp. 67–105.
- [3] J. Gaillardet, J. Viers, B. Dupré, 5.09—trace elements in river waters, in: H. Elderfield (Ed.), *Treatise on Geochemistry*, Pergamon, Oxford, 2003, pp. 225–272.
- [4] F.M.M. Morel, N.M. Price, *Science* 300 (2003) 944–947.
- [5] Y. Sohrin, K.W. Bruland, *TrAC-Trends Anal. Chem.* 30 (2011) 1291–1307.
- [6] M.P. Field, M. LaVigne, K.R. Murphy, G.M. Ruiz, R.M. Sherrell, *J. Anal. At. Spectrom.* 22 (2007) 1145–1151.
- [7] J.A. Olivares, R.S. Houk, *Anal. Chem.* 58 (1986) 20–25.
- [8] S.D. Tanner, *J. Anal. At. Spectrom.* 10 (1995) 905–921.
- [9] B.S. Garg, R.K. Sharma, N. Bhojak, S. Mittal, *Microchem. J.* 61 (1999) 94–114.
- [10] E.K.M. Ueda, P.W. Gout, L. Morganti, *J. Chromatogr. A* 988 (2003) 1–23.
- [11] M.C. Lohan, A.M. Aguilar-Islas, R.P. Franks, K.W. Bruland, *Anal. Chim. Acta* 530 (2005) 121–129.
- [12] Y. Sohrin, M. Kinugasa, K. Okamura, K. Norisuye, T. Ishita, Y. Fujishima, H. Hasegawa, K. Ueda, *Anal. Sci.* 17 (ICAS2001) (2001) i1–i4.
- [13] S.C. Pai, P.Y. Whung, R.L. Lai, *Anal. Chim. Acta* 211 (1988) 257–270.
- [14] D.B. Taylor, H.M. Kingston, D.J. Nogay, D. Koller, R. Hutton, *J. Anal. At. Spectrom.* 11 (1996) 187–191.
- [15] N.G. Beck, R.P. Franks, K.W. Bruland, *Anal. Chim. Acta* 455 (2002) 11–22.
- [16] T.Y. Ho, C.T. Chien, B.N. Wang, A. Siriraks, *Talanta* 82 (2010) 1478–1484.
- [17] Y. Sohrin, S. Urushihara, S. Nakatsuka, T. Kono, E. Higo, T. Minami, K. Norisuye, S. Umetani, *Anal. Chem.* 80 (2008) 6267–6273.
- [18] D.V. Biller, K.W. Bruland, *Mar. Chem.* 130 (2012) 12–20.
- [19] Y.B. Zhu, T. Umemura, H. Haraguchi, K. Inagaki, K. Chiba, *Talanta* 78 (2009) 891–895.
- [20] H. Takata, J. Zheng, K. Tagami, T. Aono, S. Uchida, *Talanta* 85 (2011) 1772–1777.
- [21] H. Takata, T. Aono, K. Tagami, S. Uchida, *J. Radioanal. Nucl. Chem.* 287 (2011) 795–799.
- [22] K. Norisuye, Y. Sohrin, *Anal. Chim. Acta* 727 (2012) 71–77.
- [23] M.E. Lagerstrom, M.P. Field, M. Séguret, L. Fischer, S. Hann, R.M. Sherrell, *Mar. Chem.* 155 (2013) 71–80.
- [24] G. Anderegg, *Inorg. Chim. Acta* 194 (1992) 31–35.
- [25] S. Hirata, K. Honda, O. Shikino, N. Maekawa, M. Aihara, *Spectrochim. Acta B* 55 (2000) 1089–1099.
- [26] A.M. Yusof, C.H. Chia, A.K.H. Wood, *J. Radioanal. Nucl. Chem.* 273 (2007) 533–538.
- [27] G. Bayon, D. Birot, C. Bollinger, J.A. Barrat, *Geostand. Geoanal. Res.* 35 (2011) 145–153.
- [28] A. Heimbürger, M. Tharaud, F. Monna, R. Losno, K. Desboeufs, E.B. Nguyen, *Geostand. Geoanal. Res.* 37 (2013) 77–85.
- [29] T.C.C. Rousseau, J.E. Sonke, J. Chmeleff, F. Candaudap, F. Lacan, G. Boaventura, P. Seyler, C. Jeandel, *J. Anal. At. Spectrom.* 28 (2013) 573–584.
- [30] Y. Nozaki, *Elemental distribution/Overview*, in: J.H. Steele (Ed.), *Encyclopedia of Ocean Sciences*, Academic Press, Oxford, 2001, pp. 840–845.